

PD 1447

Table of Contents

02/05/2024 Zoning Letter 2
 Exhibits 3

07/24/2019 PD Adoption 4
 Ordinance 4
 Statements 5
 Bulk Table 11
 Exhibits 13



DEPARTMENT OF PLANNING AND DEVELOPMENT
CITY OF CHICAGO

February 5, 2024

Tyler Manic
Schain Banks
70 W. Madison St., Suite 2300
Chicago, Illinois 60602

Re: PD 1447, 448 N. LaSalle Street

Dear Mr. Manic:

In response to your recent request, please be advised that the subject property is zoned Business Planned Development Number 1447 ("PD 1447") and within Subarea A. You are seeking confirmation that Electric Shuffle is an eating and drinking establishment and permitted at the subject site.

According to your request letter, Electric Shuffle combines a full-service kitchen and bar with custom built shuffle tables stationed in the restaurant. The shuffle tables are reserved online for 90-minute periods. Two people can play shuffleboard at a single time, while up to 20 guests are able to eat and drink at the table during the game. Electric Shuffle offers all-day service that includes brunch, lunch, and dinner for guests to enjoy a meal, watch sports, host a corporate outing, and play shuffleboard. A proposed Floor Plan is attached which identifies 76% of the 6,024 square foot space for eating and drinking and 11% for shuffle tables.

Based on the information submitted, it is our opinion that the proposed Electric Shuffle use is an eating and drinking establishment. Pursuant to Statement No. 6 of PD 1447, the permitted uses within Subarea A include eating and drinking establishments. Therefore, the proposed use is permitted at the subject site.

Sincerely,

Patrick Murphey
Zoning Administrator

PM:tm

C: Noah Szafranec, Mike Marmo, Janice Hill, Main file

10/13/2023

OCCUPANCY TYPE	OCCUPANTS	SQUARE FOOTAGE	PERCENTAGE BY OCCUPANTS	PERCENTAGE BY SF
CIRCULATION	48 / 3 = 16*	716 SF / 3 = 239 SF*	NA	NA
EATING & DRINKING	255 + 16 = 271	1,939 + 239 = 2,178 SF	75%	35%
SHUFFLE TABLES	22 + 16 = 38	813 + 239 = 1,052 SF	11%	18%
KITCHEN / BAR	11	2,015 SF	3%	33%
BAR GUEST	15 + 16 = 31	96 + 239 = 337 SF	9%	6%
BACK OF HOUSE	5	412 SF	1%	7%
TOTAL	356 OCCUPANTS	6,024 SF		

*CIRCULATION CALCULATIONS EQUALLY DISTRIBUTED TO
 - EATING & DRINKING
 - SHUFFLE TABLES
 - BAR GUEST

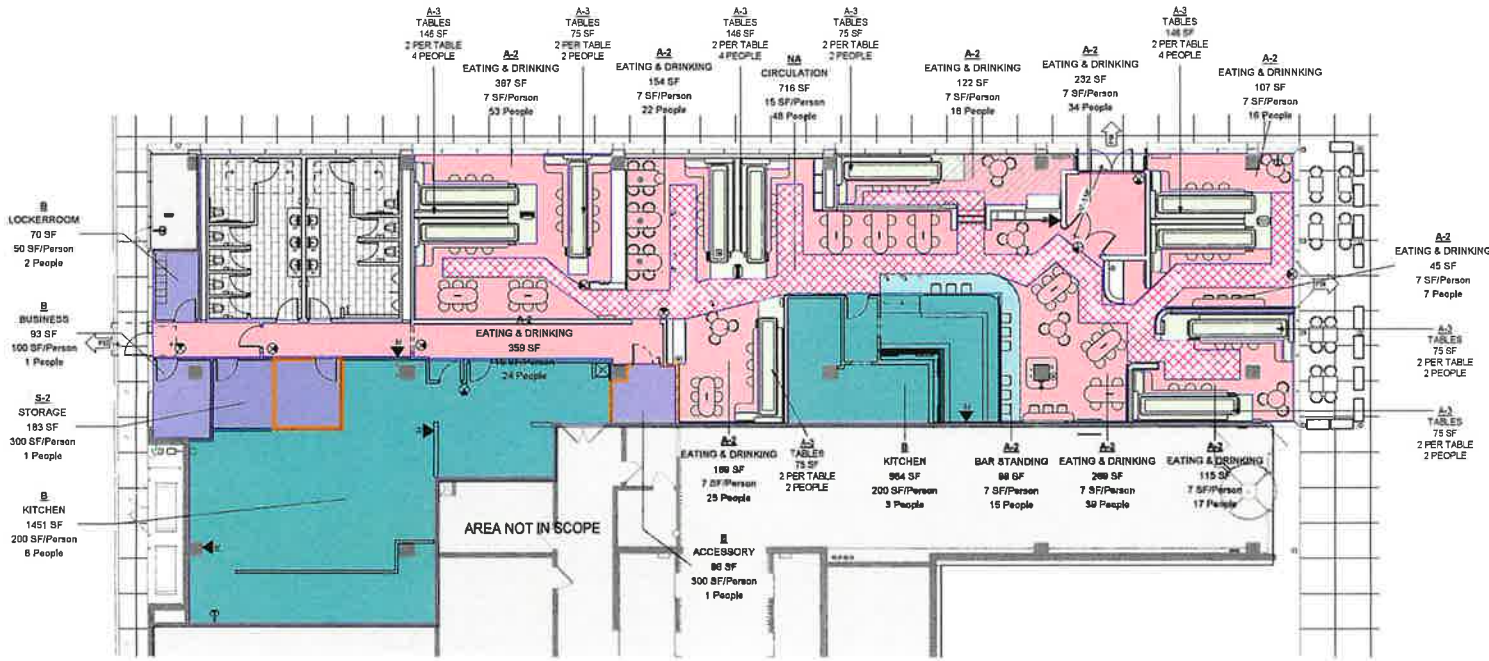

10/13/2023 UNLOCKED.DWG

271 Columbia Center Dr
 38, Cook, IL 60612
 P (708) 852-5181

ARCO MURRAY

3112 Westmore Dr
 Chicago, IL 60618
 P (708) 251-7777
 www.arcomurray.com

NO.	DATE	DESCRIPTION
1	10/13/2023	ISSUED FOR CONSTRUCTION
2		
3		
4		
5		
6		
7		
8		
9		
10		

ELECTRIC SHUFFLE

PROJECT
ELECTRIC SHUFFLE
 448 N. LA SALLE DR - SUITE #
 CHICAGO, IL 60654

NOT FOR CONSTRUCTION
 12/06/2023

JOB NO. 04152
 FA Author
 ISSUE DATE 10/18/2023

NO.	DATE	DESCRIPTION
1	10/18/2023	ISSUED FOR CONSTRUCTION
2		
3		
4		
5		
6		
7		
8		
9		
10		

SHEET NUMBER
A12.2
 ZONING PLAN

1 ZONING PLAN
 SCALE 1/8" = 1'-0"

19944

7/24/2019

REPORTS OF COMMITTEES

3917

Page 11 also contains the historical landmark designation for the Rainbow Pylons and the Legacy Walk located at 3244 -- 3710 North Halsted Street and 3243 -- 3711 North Halsted Street in the 44th and 46th Wards.

Page 12 contains various large signs over 100 square feet in area and 24 feet above grade in the 1st, 11th, 28th, 32nd, 39th, 41st, 42nd, 44th and 50th Wards.

I hereby move for passage of the proposed ordinances and substitute ordinances transmitted herewith.

Respectfully submitted,

(Signed) THOMAS TUNNEY,
Chairman.

On motion of Alderman Tunney, the said proposed ordinances and substitute ordinances transmitted with the foregoing committee report were *Passed* by yeas and nays as follows:

Yeas -- Aldermen La Spata, Hopkins, Dowell, King, Hairston, Sawyer, Mitchell, Harris, Beale, Sadlowski Garza, Thompson, Cárdenas, Quinn, Burke, Lopez, Coleman, Moore, Curtis, O'Shea, Taylor, Brookins, Rodriguez, Tabares, Scott, Sigcho-Lopez, Maldonado, Burnett, Ervin, Taliaferro, Reboyras, Cardona, Waguespack, Rodriguez-Sanchez, Austin, Ramirez-Rosa, Villegas, Mitts, Sposato, Nugent, Vasquez, Napolitano, Reilly, Smith, Tunney, Gardiner, Cappleman, Martin, Osterman, Hadden, Silverstein -- 50.

Nays -- None.

Alderman Thompson moved to reconsider the foregoing vote. The motion was lost.

The following are said ordinances as passed (the italic heading in each case not being a part of the ordinance):

Reclassification Of Area Shown On Map No. 1-F. BPD 1447
(As Amended)
(Application No. 19944)
(Common Address: 151 W. Illinois St./450 -- 500 N. LaSalle St.)
[SO2019-328]

Be It Ordained by the City Council of the City of Chicago:

SECTION 1. Title 17 of the Municipal Code of Chicago, the Chicago Zoning Ordinance, is hereby amended by changing all of the DX-7 Downtown Mixed-Use District as shown on Map Number 1-F in the area bounded by:

the public alley next north of West Illinois Street; North LaSalle Street; a line 40 feet north of the public alley next south of West Illinois Street; a line 60.06 feet west of North LaSalle Street; the public alley next south of West Illinois Street; the public alley next west of North LaSalle Street; a line 92.40 feet west of and parallel to North LaSalle Street; and a line 54.19 feet south of and parallel to the public alley next north of West Illinois Street to the point of the beginning,

to those of a Business Planned Development.

SECTION 2. This ordinance takes effect after its passage and publication.

Plan of Development Statements attached to this ordinance read as follows:

Business Planned Development No. 1447.

Planned Development Statements.

1. The area delineated herein as Business Planned Development Number 1447 ("Planned Development") consists of approximately 21,625.59 square feet of property which is depicted on the attached Planned Development Boundary and Property Line Map ("Property") and is owned or controlled by the Applicant, 430 North LaSalle LLC.
2. The requirements, obligations and conditions contained within this Planned Development shall be binding upon the Applicant, its successors and assigns and, if different than the Applicant, the legal titleholders and any ground lessors. All rights granted hereunder to the Applicant shall inure to the benefit of the Applicant's successors and assigns and, if different than the Applicant, the legal titleholder and any ground lessors. Furthermore, pursuant to the requirements of Section 17-8-0400 of the Chicago Zoning Ordinance, the Property, at the time of application for amendments, modifications or changes (administrative, legislative or otherwise) to this Planned Development are made, shall be under single ownership or designated control. Single designated control is defined in Section 17-8-0400 of the Zoning Ordinance.
3. All applicable official reviews, approvals or permits are required to be obtained by the Applicant or its successors, assignees or grantees. Any dedication or vacation of streets or alleys or grants of easements or any adjustment of the right-of-way shall require a separate submittal to the Department of Transportation on behalf of the Applicant or its successors, assigns or grantees. Any requests for grants of privilege, or any items encroaching on the public way, shall be in compliance with the plans.

Ingress or egress shall be pursuant to the plans and may be subject to the review and approval of the Departments of Planning and Development, and Transportation. Closure of all or any public street or alley during demolition or construction shall be subject to the review and approval of the Department of Transportation.

Pursuant to a negotiated and executed Perimeter Restoration Agreement ("Agreement") by and between the Department of Transportation's Division of Infrastructure Management and the Applicant, the Applicant shall provide improvements and restoration of all public way adjacent to the property, which may include, but not be limited to, the following as shall be reviewed and determined by the Department of Transportation's Division of Infrastructure Management:

- Full width of streets
- Full width of alleys
- Curb and gutter
- Pavement markings
- Sidewalks
- ADA crosswalk ramps
- Parkway and landscaping

The Perimeter Restoration Agreement must be executed prior to any Department of Transportation and Planned Development Part II Review permitting. The Agreement shall reflect that all work must comply with current Rules and Regulations and must be designed and constructed in accordance with the Department of Transportation's Construction Standards for Work in the Public Way and in compliance with the Municipal Code of Chicago Chapter 10-20. Design of said improvements should follow the Department of Transportation's Rules and Regulations for Construction in the Public Way as well as The Street and Site Plan Design Guidelines. Any variation in scope or design of public way improvements and restoration must be approved by the Department of Transportation.

The Applicant shall employ an alley-dock manager who will be on-premises who shall be responsible for overseeing the daily operations of the office building at 151 West Illinois Street/488 North LaSalle Street ("Office Building"), including managing the security and maintenance of the East/West Alley (the "Alley") and the loading dock for the Office Building. The alley-dock manager shall be separate from the property manager for the Office Building and shall report directly to the property manager. The alley-dock manager shall monitor the Office Building's use of and operations in the Alley and the loading dock during regular business hours from 8:30 A.M. to 5:50 P.M. unless otherwise needed. Loadings will be scheduled through

the alley-dock manager during normal business hours. A time limit should be enforced for vehicles on the loading dock to 30 minutes. The loading dock's use is limited to trucks no greater than 25 feet during business hours. Any delivery to the Office Building absolutely requiring a truck over 25 feet in length will require special reservations/arrangements. Also, any delivery to the Office Building requiring more than 30 minutes of parking in the loading dock will also require a special reservation. No loading to the Office Building from the Alley shall occur except for within the Office Building's loading dock. The Applicant shall install security cameras overlooking the Alley and the loading dock for the alley-dock manager to regulate and monitor the Office Building's deliveries and traffic flows of the Alley and loading dock during business hours. The obligation to employ an alley-dock manager to monitor and regulate the Alley and loading dock in accordance with this statement shall remain a responsibility for all future owners of the Office Building.

4. All applicable official reviews, approvals or permits are required to be obtained by the Applicant or its successors, assignees or grantees. Any dedication or vacation of streets or alleys or grants of easements or any adjustment of the right-of-way shall require a separate submittal to the Department of Transportation on behalf of the Applicant or its successors, assigns or grantees.

Any requests for grants of privilege, or any items encroaching on the public way, shall be in compliance with the Plans.

Ingress or egress shall be pursuant to the Plans and may be subject to the review and approval of the Departments of Planning and Development and Transportation. Closure of all or any public street or alley during demolition or construction shall be subject to the review and approval of the Department of Transportation.

All work proposed in the public way must be designed and constructed in accordance with the Department of Transportation Construction Standards for Work in the Public Way and in compliance with the Municipal Code of the City of Chicago. Prior to the issuance of any Part II Approval, the submitted plans must be approved by the Department of Transportation.

5. This plan of development consists of 18 Statements; a Bulk Regulations Table; an Existing Zoning and Land-Use Map; a Planned Development Boundary, Subarea and Property Line Map; Site/Right-of-Way Adjustment Map; Landscape Plan; Building Elevations (North, South, East and West); Floor Plans; and Building Sections prepared by Lamar Johnson Collaborative and dated April 18, 2019, submitted herein. Full-sized copies of the Site Plan, Landscape Plan and Building Elevations are on file with the Department of Planning and Development. In any instance where a provision of this Planned Development conflicts with the Chicago Building Code, the Building Code shall control. This Planned Development conforms to the intent and purpose of the Zoning Ordinance, and all requirements thereto, and satisfies the established criteria for approval as a Planned Development. In case of a conflict between the terms of this Planned Development ordinance and the Zoning Ordinance, this Planned Development ordinance shall control.
6. The following uses are permitted in the Subarea A and Subarea B delineated herein as the Planned Development:

Subarea A:

General retail sales, office, eating and drinking establishments, personal service, co-located wireless communication facilities, cultural exhibits and libraries, animal services, artists work or sales space, business equipment sales and service, business support services, communication service establishments, financial services, food and beverage retail sales, medical service, artisan manufacturing uses, including accessory and related uses as well as accessory loading.

Subarea B:

General retail sales, office, eating and drinking establishments, personal service, co-located wireless communication facilities, cultural exhibits and libraries, animal services, artists work or sales space, business equipment sales and service, business support services, communication service establishments, financial services, food and beverage retail sales, medical service, artisan manufacturing uses, including accessory and related uses as well as accessory loading.

7. On-premises signs and temporary signs, such as construction and marketing signs, shall be permitted within the Planned Development, subject to the review and approval of the Department of Planning and Development.
8. For purposes of height measurement, the definitions in the Zoning Ordinance shall apply. The height of any building shall also be subject to height limitations, if any, established by the Federal Aviation Administration.
9. The maximum permitted Floor Area Ratio ("FAR") for the site shall be in accordance with the attached Bulk Regulations Table. For the purposes of FAR calculations and measurements, the definitions in the Zoning Ordinance shall apply. The permitted FAR identified in the Bulk Regulations Table has been determined using a Net Site Area of 21,625.59 square feet.

The Applicant acknowledges that the project has received a bonus FAR of 2.326, pursuant to Section 17-4-1000 of the Zoning Ordinance. With this bonus FAR, the total FAR for the Planned Development is 9.236. In exchange for the bonus FAR, the Applicant is required to make a corresponding payment, pursuant to Sections 17-4-1003-B and C, prior to issuance of the first building permit for any building in the Planned Development; provided, however, if the Planned Development is constructed in phases, the bonus may be paid on a pro rata basis as the first building permit for each subsequent new building or phase of construction is issued. The bonus payment will be recalculated at the time of payment (including partial payments for phased developments) and may be adjusted based on changes in median land values in accordance with Section 17-4-1003-C.3.

The bonus payment will be split between three separate funds, as follows: 80 percent to the Neighborhoods Opportunity Fund, 10 percent to the Citywide Adopt-a-Landmark Fund and 10 percent to the Local Impact Fund, pursuant to Section 17-4-1003-D. Such funds will be utilized pursuant to Section 17-4-1004-B (Neighborhoods Opportunity), Section 17-4-1006-C (Citywide Adopt-a-Landmark) and Section 17-4-1005-C (Local Impact).

10. Upon review and determination, "Part II Review", pursuant to Section 17-13-0610 of the Zoning Ordinance, a Part II Review fee shall be assessed by the Department of Planning and Development. The fee, as determined by staff at the time, is final and binding on the Applicant and must be paid to the Department of Revenue prior to the issuance of any Part II Approval.
11. The Site and Landscape Plans shall be in substantial conformance with the Landscape Ordinance and any other corresponding regulations and guidelines. Final landscape plan review and approval will be by the Department of Planning and Development. Any interim reviews associated with site plan review or Part II Reviews, are conditional until final Part II Approval.
12. The Applicant shall comply with Rules and Regulations for the Maintenance of Stockpiles promulgated by the Commissioners of the Departments of Streets and Sanitation, Fleet and Facility Management and Buildings, under Section 13-32-125 of the Municipal Code, or any other provision of that Code.
13. The terms and conditions of development under this Planned Development ordinance may be modified administratively, pursuant to Section 17-13-0611-A of the Zoning Ordinance by the Zoning Administrator upon the application for such a modification by the Applicant, its successors and assigns and, if different than the Applicant, the legal titleholders and any ground lessors.
14. The Applicant acknowledges that it is in the public interest to design, construct and maintain the project in a manner which promotes, enables and maximizes universal access throughout the Property. Plans for all buildings and improvements on the Property shall be reviewed and approved by the Mayor's Office for People with Disabilities to ensure compliance with all applicable laws and regulations related to access for persons with disabilities and to promote the highest standard of accessibility. No building permit shall be issued by the Department of Construction and Permits until the Director of MOPD has approved detailed construction drawings for the building or improvement proposed.
15. The Applicant acknowledges that it is in the public interest to design, construct, renovate and maintain all buildings in a manner that provides healthier indoor environments, reduces operating costs and conserves energy and natural resources. At the time of a hearing before the Chicago Plan Commission, all developments must be in substantial compliance with the current City of Chicago Sustainable Development Policy set forth by the Department of Planning and Development.

16. Chicago Landmark/Chicago Landmark District Pursuant to the Chicago Zoning Ordinance (Section 17-8-0911), a Planned Development (P.D.) gives priority to the preservation and adaptive reuse of Chicago landmark buildings. The P.D. includes LaSalle Street Cable Car Powerhouse, which is designated as a Chicago landmark or has been identified as contributing to the historic. Work to designated Chicago landmarks is subject to the review and approval of the Commission on Chicago Landmarks pursuant to the Chicago Landmarks Ordinance, Section 2-120-740.

Prior to submitting an application for a building permit for the project, the applicant shall submit the report of a licensed structural engineer to the Historic Preservation Division of the Department of Planning and Development for its acceptance. The report shall include recommendations for protection or stabilization measures to be taken during construction regarding the adjacent Vesemen Building, a designated Chicago landmark, at 444 North LaSalle Drive.

17. The Applicant acknowledges that it is the policy of the City to maximize opportunities for Minority- and Women-owned Business Enterprises ("M/WBEs") and City residents to compete for contracts and jobs on construction projects approved through the planned development process. To assist the City in promoting and tracking such M/WBE and City resident participation, an applicant for planned development approval shall provide information at three points in the City approval process. First, the applicant must submit to DPD, as part of its application for planned development approval, an M/WBE Participation Proposal. The M/WBE Participation Proposal must identify the applicant's goals for participation of certified M/WBE firms in the design, engineering and construction of the project, and of City residents in the construction work. The City encourages goals of (i) 26 percent MBE and 6 percent WBE participation (measured against the total construction budget for the project or any phase thereof), and (ii) 50 percent City resident hiring (measured against the total construction work hours for the project or any phase thereof). The M/WBE Participation Proposal must include a description of the applicant's proposed outreach plan designed to inform M/WBEs and City residents of job and contracting opportunities. Second, at the time of the applicant's submission for Part II Permit Review for the project or any phase thereof, the Applicant must submit to DPD (a) updates (if any) to the applicant's preliminary outreach plan, (b) a description of the applicant's outreach efforts and evidence of such outreach, including, without limitation, copies of certified letters to M/WBE contractor associations and the ward office of the alderman in which the project is located and receipts thereof; (c) responses to the applicant's outreach efforts, and (d) updates (if any) to the applicant's M/WBE and City resident participation goals. Third, prior to issuance of a Certificate of Occupancy for the project or any phase thereof, the applicant must provide DPD with the actual level of M/WBE and City resident participation in the project or any phase thereof, and evidence of such participation. In addition to the foregoing, DPD may request such additional information as the department determines may be necessary or useful in evaluating the extent to which M/WBEs and City residents are informed of and utilized in planned development projects. All such information will be provided in a form acceptable to the Zoning Administrator. DPD will report the data it collects regarding projected and actual employment of M/WBEs and City residents in planned development projects twice yearly to the Chicago Plan Commission and annually to the Chicago City Council and the Mayor.

19944

- 18. This Planned Development shall be governed by Section 17-13-0612 of the Zoning Ordinance. Should this Planned Development ordinance lapse, the Commissioner of the Department of Planning and Development shall initiate a zoning map amendment to rezone the Property to DX-7 Downtown Mixed-Use District.

[Parcel Diagram; Zoning FAR Analysis; Vicinity Plan; Existing Zoning Map; Existing Land-Use Map; Site Plan; First Floor Plan; Mezzanine Plan; Green Roof Plan; Landscape Tree Removal; Landscape Plan; Landscape Details; North, South, East and West Building Elevations; Contextual Renderings; Existing Site Photos; Subareas A and B Surveys; Subarea B Floor Plan -- 500 North LaSalle Street; and Subarea B Elevations -- 500 North LaSalle Street referred to in these Plan of Development Statements printed on pages 3926 through 3947 of this *Journal*.]

Bulk Regulations and Data Table referred to in these Plan of Development Statements reads as follows:

Business Planned Development No. 1447.

Bulk Regulations And Data Table.

Net Site Area:

Subarea A:	15,472.00 square feet
Subarea B:	6,153.59 square feet
Total Net Site Area:	21,625.59 square feet

Existing Building Area:

Subarea A:	15,600.00 square feet
Total Existing Building Area:	15,600.00 square feet

Area of Proposed Building:

Subarea A:	15,600.00 square feet (existing to remain)
Subarea B:	186,081.00 square feet
Total Proposed Building Area:	201,681.00 square feet

Floor Area Ratio:

FAR Subarea A:	0.721 (existing)
FAR Subarea B:	8.605
Bonus FAR to purchase:	2.326
Total Project FAR:	9.326

Maximum Allowable Floor Area:

Maximum Floor Area Subarea A:	15,600.00 square feet
Maximum Floor Area Subarea B:	186,081.00 square feet
Total Maximum Floor Area:	201,681.00 square feet

Setbacks: In accordance with Site Plan

Maximum Building Height: 188.00 feet

Minimum Parking Spaces:

Subarea A:	0 (existing no change)
Subarea B:	0 (transit served location)

Bicycle Parking Spaces:

Subarea A:	0 (existing -- no change)
Subarea B:	50

Loading Spaces:

Subarea A:	0 (existing -- no change)
Subarea B:	1 (10 feet by 25 feet)

Final for Publication

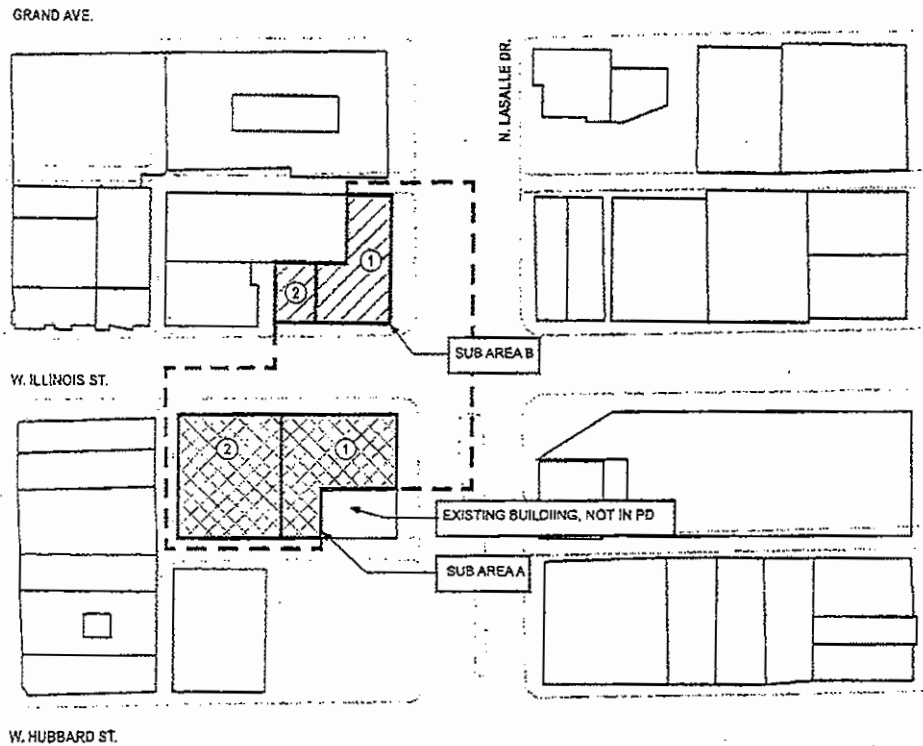

SUB AREA A (151 W ILLINOIS):
PARCEL 1+2 - 15,472.00 SF

SUB AREA B (430 - 500 N LASALLE DR):
PARCEL 1+2 - 6,153.59 SF

TOTAL: - 21,625.59 SF

PARCEL DIAGRAM

Applicant: 430 North LaSalle LLC
Address: 151 W Illinois; 430 - 500 N LaSalle Drive
Introduced: January 23, 2019
CPC Date: April 18, 2019



FINAL FOR PUBLICATION

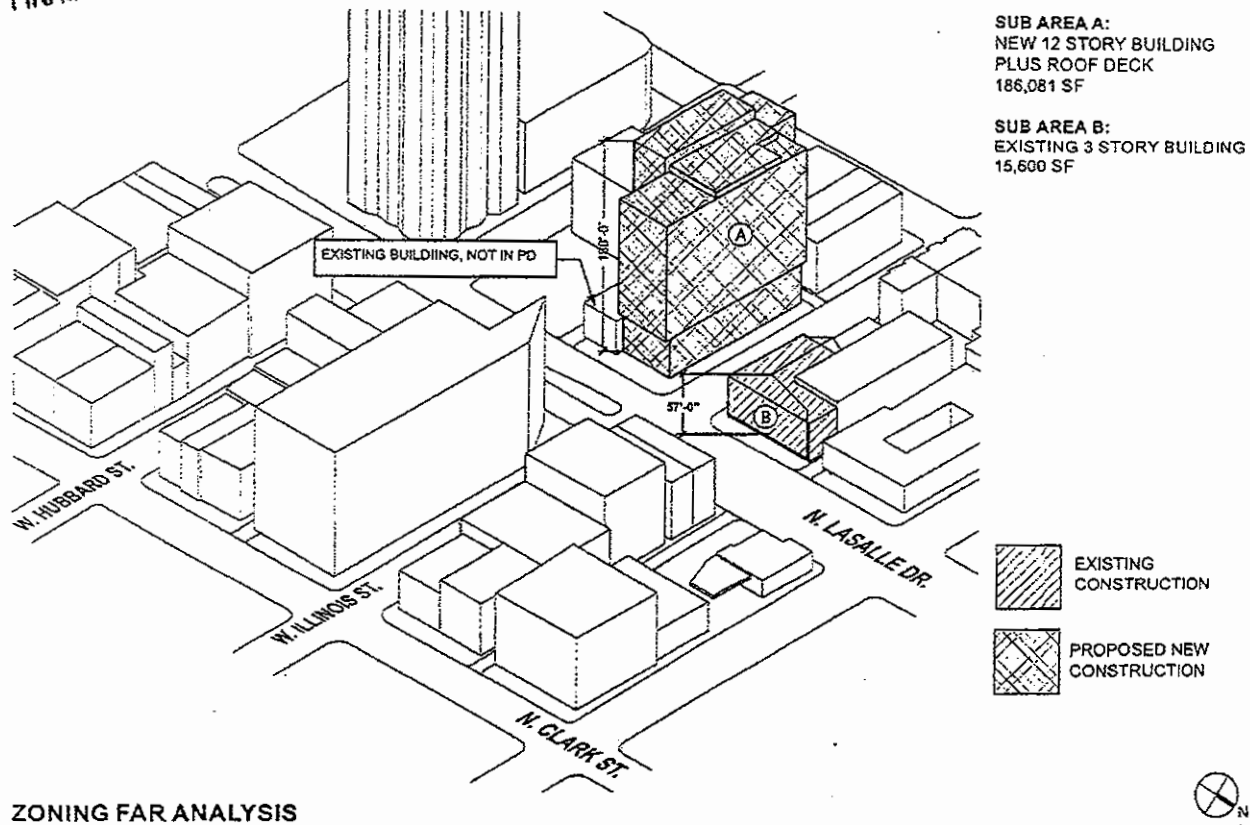

ZONING FAR ANALYSIS

Applicant: 430 North LaSalle LLC
 Address: 151 W Illinois; 430 - 500 N LaSalle Drive
 Introduced: January 23, 2019
 CPC Date: April 18, 2019



Final for Publication

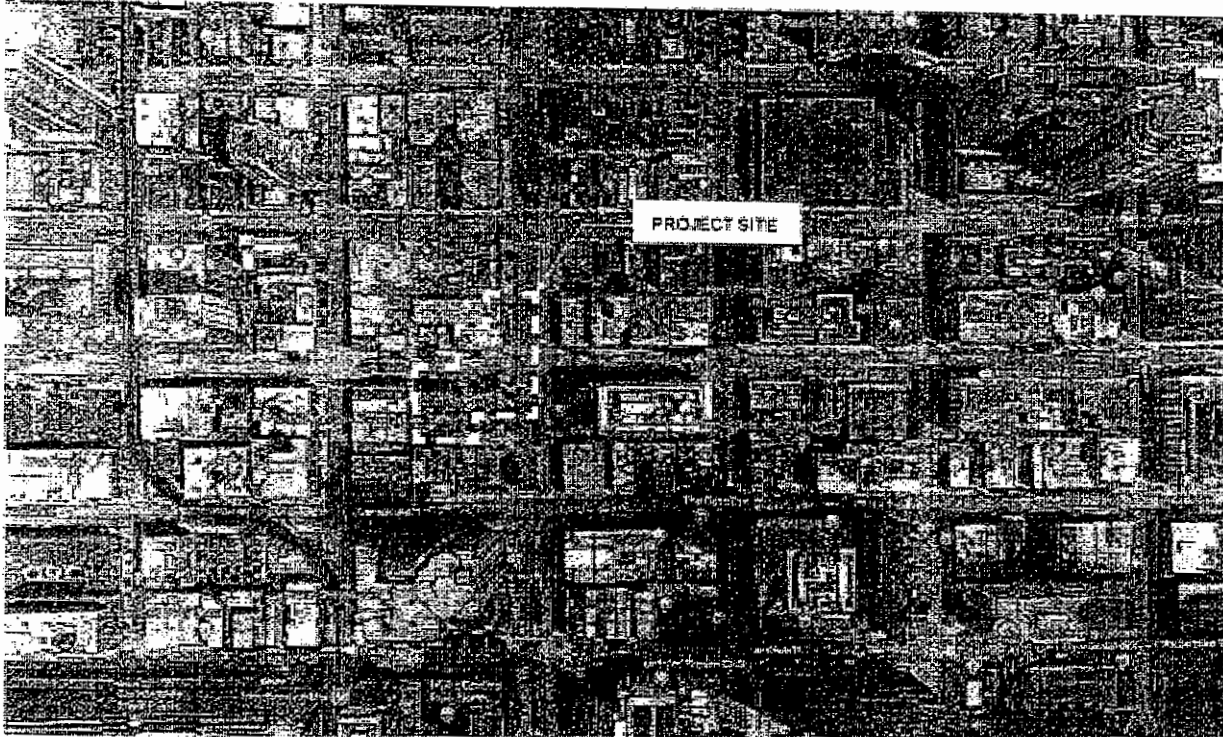

VICINITY PLAN



Applicant: 430 North LaSalle LLC
Address: 151 W Illinois, 430 - 500 N LaSalle Drive
Introduced: January 23, 2019
CPC Date: April 18, 2019



Final for Publication

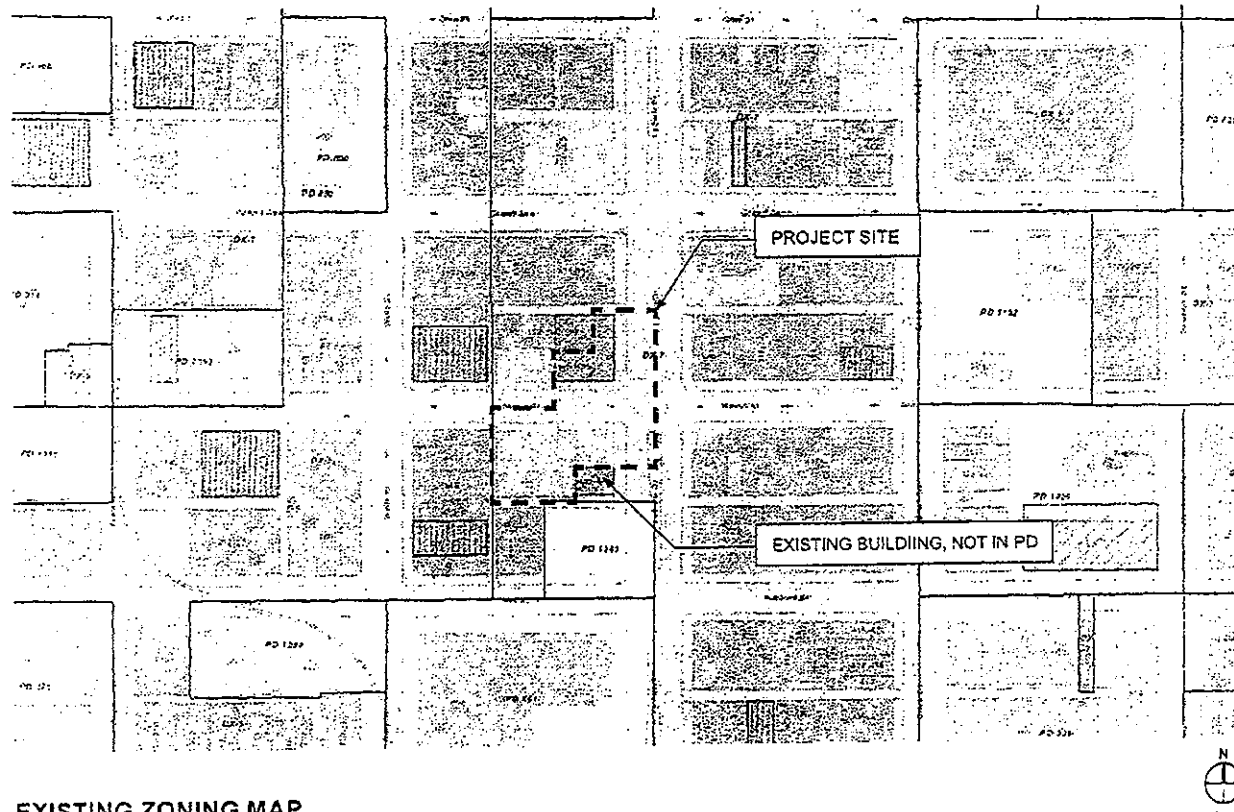

EXISTING ZONING MAP

Applicant: 430 North LaSalle LLC
 Address: 151 W Illinois; 430 - 500 N LaSalle Drive
 Introduced: January 23, 2019
 CPC Date: April 18, 2019



Final for Publication

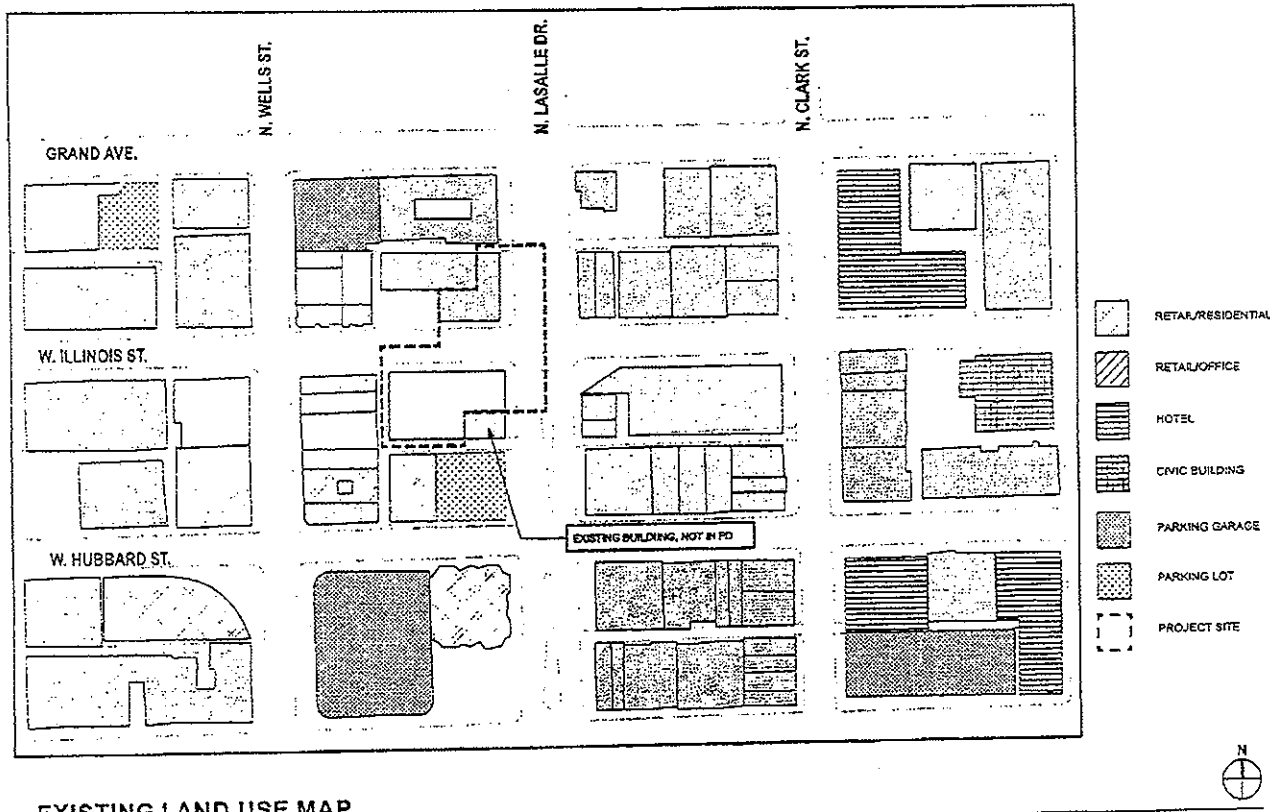

EXISTING LAND USE MAP

Applicant: 430 North LaSalle LLC
 Address: 151 W Illinois; 430 - 500 N LaSalle Drive
 Introduced: January 23, 2019
 CPC Date: April 18, 2019



Final for Publication

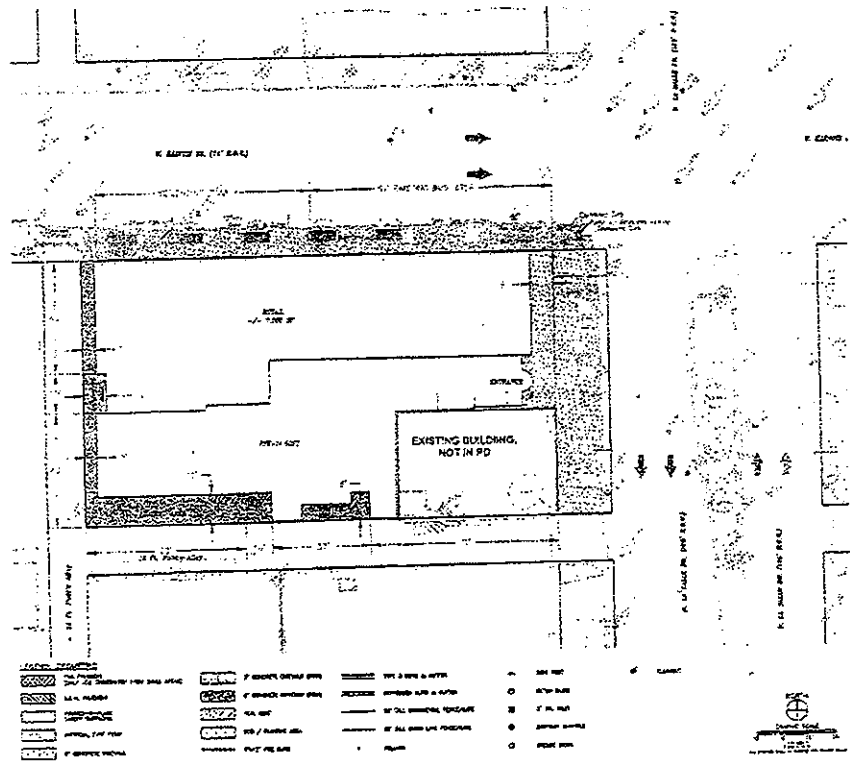

SITE PLAN

Applicant: 430 North LaSalle LLC
 Address: 151 W Illinois: 430 - 500 N LaSalle Drive
 Introduced: January 23, 2019
 CPC Date: April 18, 2019

Final for Publication

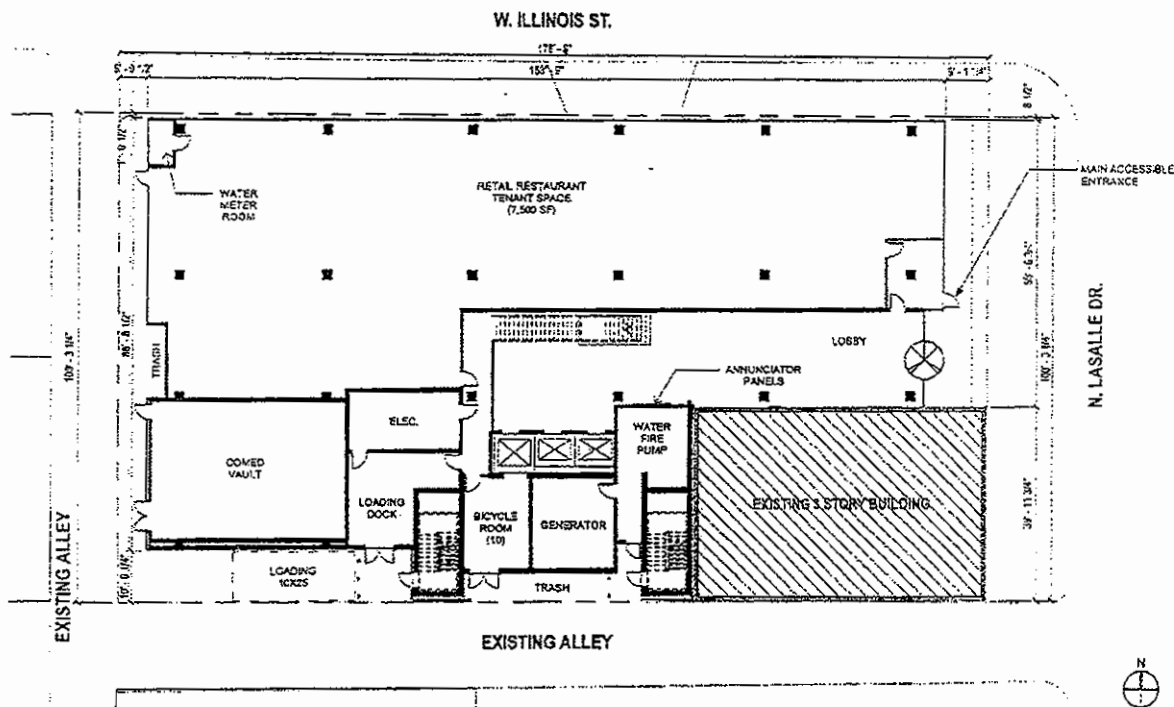

FIRST FLOOR PLAN

Applicant: 430 North LaSalle LLC
 Address: 151 W Illinois; 430 - 500 N LaSalle Drive
 Introduced: January 23, 2019
 CPC Date: April 18, 2019



FINAL FOR PUBLICATION

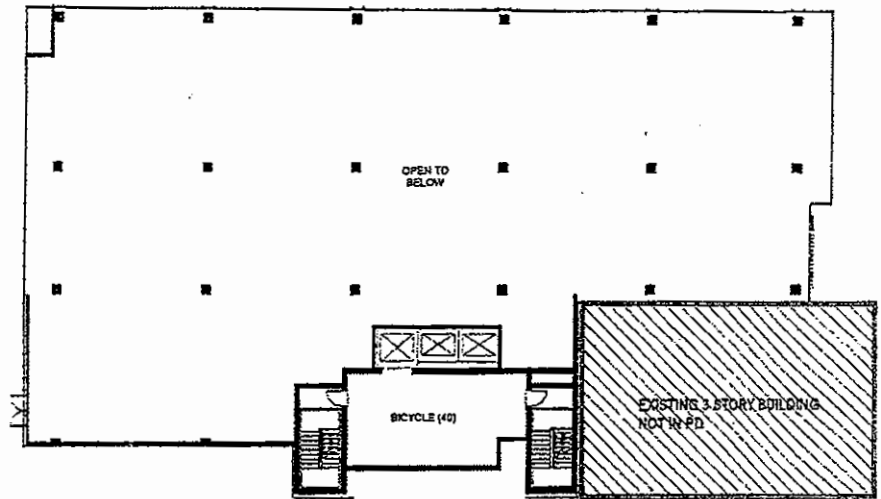



MEZZANINE PLAN

Applicant: 430 North LaSalle LLC
 Address: 151 W Illinois; 430 - 500 N LaSalle Drive
 Introduced: January 23, 2019
 CPC Date: April 18, 2019

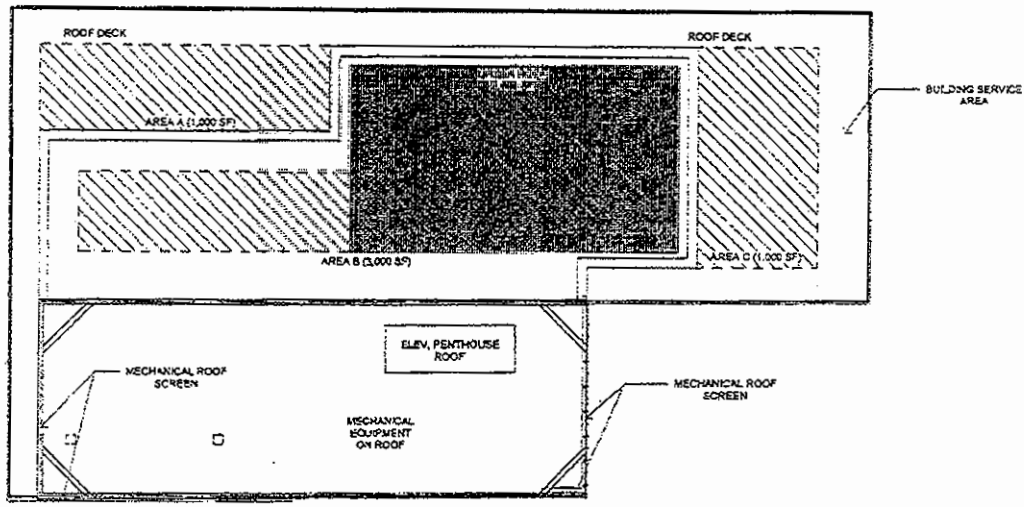

Final for Publication



 NET ROOF AREA . . . 5,050 SF
 GREEN ROOF AREA 2,600 SF

GREEN ROOF PLAN



Applicant: 430 North LaSalle LLC
 Address: 151 W Illinois; 430 - 500 N LaSalle Drive
 Introduced: January 23, 2019
 CPC Date: April 18, 2019

Final for Publication

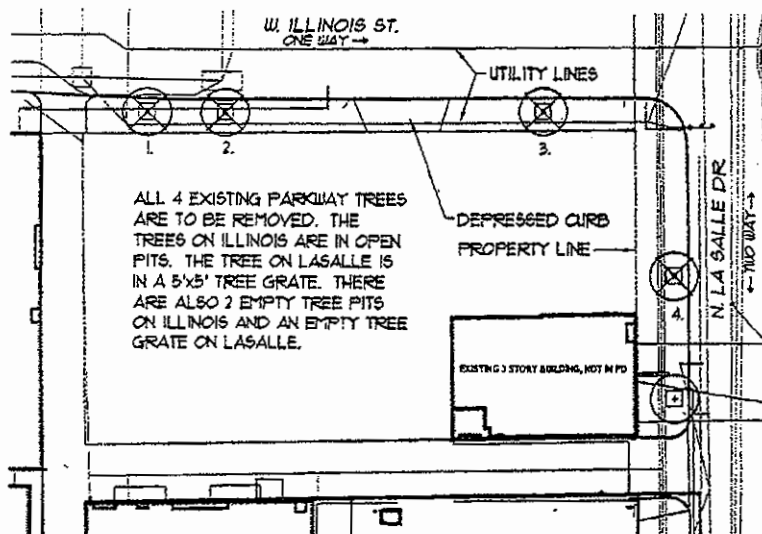

TREE 1



TREE 2



TREE 3



TREE 4

PARKWAY TREE REMOVAL LIST

CODE	BOTANICAL NAME	COMMON NAME	SIZE	CONDITION
1	GLEDITSIA TRIACANTHOS INERMIS	THORNLESS HONEYLOCUST	11" CAL.	GOOD
2	GLEDITSIA TRIACANTHOS INERMIS	THORNLESS HONEYLOCUST	11" CAL.	GOOD
3	GLEDITSIA TRIACANTHOS INERMIS	THORNLESS HONEYLOCUST	13" CAL.	GOOD
4	ULMUS SPECIES	ELM VARIETY	8" CAL.	GOOD



LANDSCAPE TREE REMOVAL

Applicant: 430 North LaSalle LLC
 Address: 151 W Illinois; 430 - 500 N LaSalle Drive
 Introduced: January 23, 2019
 CPC Date: April 18, 2019



Final for Publication

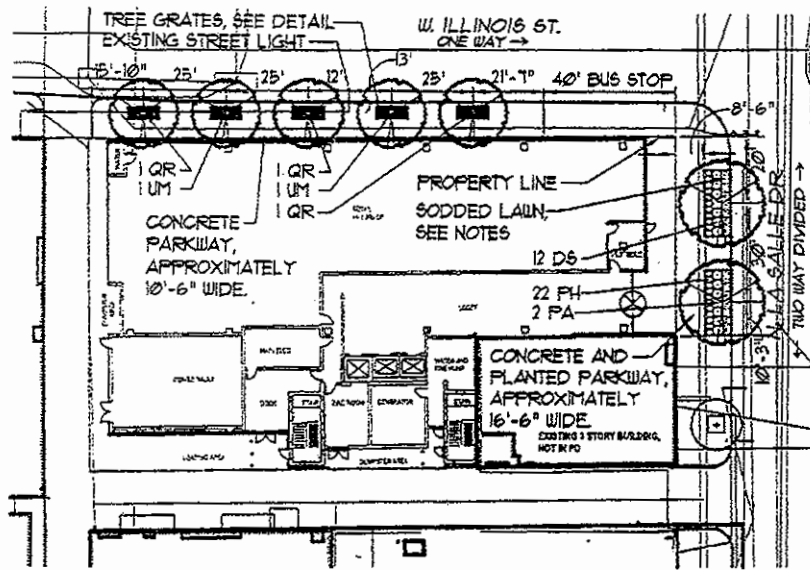

PROPOSED PARKWAY DIMENSIONS:

WEST ILLINOIS STREET
 APPROXIMATE PARKWAY WIDTH = 10'-6"
 PROPERTY LINE TO TREE GRATE = 5'-6"
 TREE GRATE WIDTH = 4'-0"
 CARRIAGE WALK WIDTH = 1'-0"

NORTH LA SALLE DRIVE
 APPROXIMATE PARKWAY WIDTH = 16'-6"
 PROPERTY LINE TO PLANT BED = 8'-6"
 PLANT BED WIDTH = 8'-0"

NOTES: PARKWAY TREES ON LA SALLE ARE TO BE SET WITH CENTER OF TRUNKS 5' OFF OF EDGE OF 24" WATER MAIN, AND 30" OFF OF BACK OF CURB. LAWN STRIPS ALONG LA SALLE TO BE 20' LONG AND 7'-6" WIDE. PARKWAY PLANTER BEDS TO BE EXCAVATED TO A DEPTH OF 24" AND BACKFILLED WITH PREMIUM TOPSOIL. LAWN GRASS TO BE A TALL FESCUE SOD BLEND SUCH AS BLACK BEAUTY.

PLANT LIST

CODE	BOTANICAL NAME	COMMON NAME	SIZE	TOTAL	COMMENTS
PA	PLATANUS ACERIFOLIA 'MORTON CIRCLE'	EXCLAMATION PLANTREE	4" CAL.	2	BRANCHED UP 6'
QR	QUERCUS X WAREI 'LONG'	REGAL PRINCE OAK	4" CAL.	3	BRANCHED UP 6'
UM	ULMUS MINOR 'NEW HORIZON'	NEW HORIZON ELM	4" CAL.	2	BRANCHED UP 6'
DS	DIERVILLA SESSILIFOLIA 'BUTTERFLY'	BUTTERFLY HONEYSUCKLE	3 GAL.	12	18" MIN SPREAD
PH	PENNISETUM ALOPECUROIDES 'HAMELN'	DWARF FOUNTAIN GRASS	1 GAL.	22	SPACED 24" OC.

LANDSCAPE PLAN

Applicant: 430 North LaSalle LLC
 Address: 151 W Illinois; 430 - 500 N LaSalle Drive
 Introduced: January 23, 2019
 CPC Date: April 18, 2019



Final for Publication

7/24/2019

REPORTS OF COMMITTEES

LOCATE ALL UNDERGROUND UTILITIES PRIOR TO DIGGING. TREE PIT WIDTH TO BE EXTENDED 12" AROUND THE ENTIRE ROOT BALL AS SHOWN IN THE DETAIL BELOW. TEST TREE PIT FOR DRAINAGE PRIOR TO INSTALLING TREE. PRUNE OFF ALL DEAD, BROKEN OR SCARRED BRANCHES, AND SHAPE PRUNE AS DIRECTED BY THE LANDSCAPE ARCHITECT. FOR TREES UP TO 4" CALIPER OR 12' HEIGHT, REMOVE APPROXIMATELY 5% -10% OF THE OVERALL BRANCHING. FOR TREES OVER 4" CALIPER OR 12' HEIGHT, REMOVE APPROXIMATELY 15%-20% OF THE OVERALL BRANCHING. LOCATE ROOT FLARE IN ROOT BALL AND SET TREE HEIGHT SO THAT ROOT FLARE IS FLUSH WITH THE PLANTING MIX. WATER IN THE PLANTING MIX THOROUGHLY, WHILE KEEPING THE TREE PLUMB. STRAIGHTEN TREE IF SETTLING OCCURS. CONTRACTOR TO REMOVE ALL TWINE, ROPE, BASKET WIRE AND BURLAP FROM THE TOP HALF OF THE ROOT BALL.

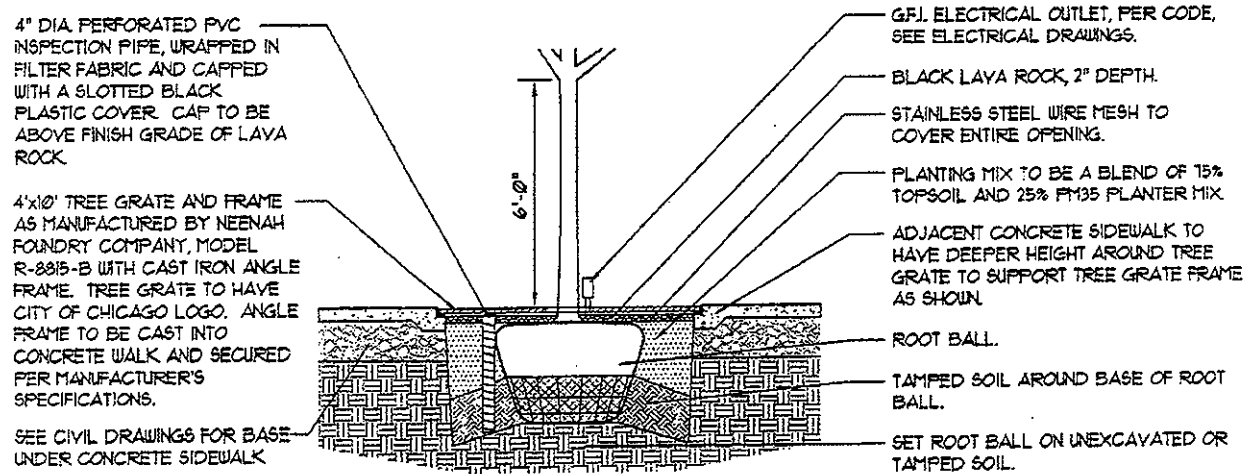

LANDSCAPE DETAILS

Applicant: 430 North LaSalle LLC
 Address: 151 W Illinois; 430 - 500 N LaSalle Drive
 Introduced: January 23, 2019
 CPC Date: April 18, 2019



Final for Publication

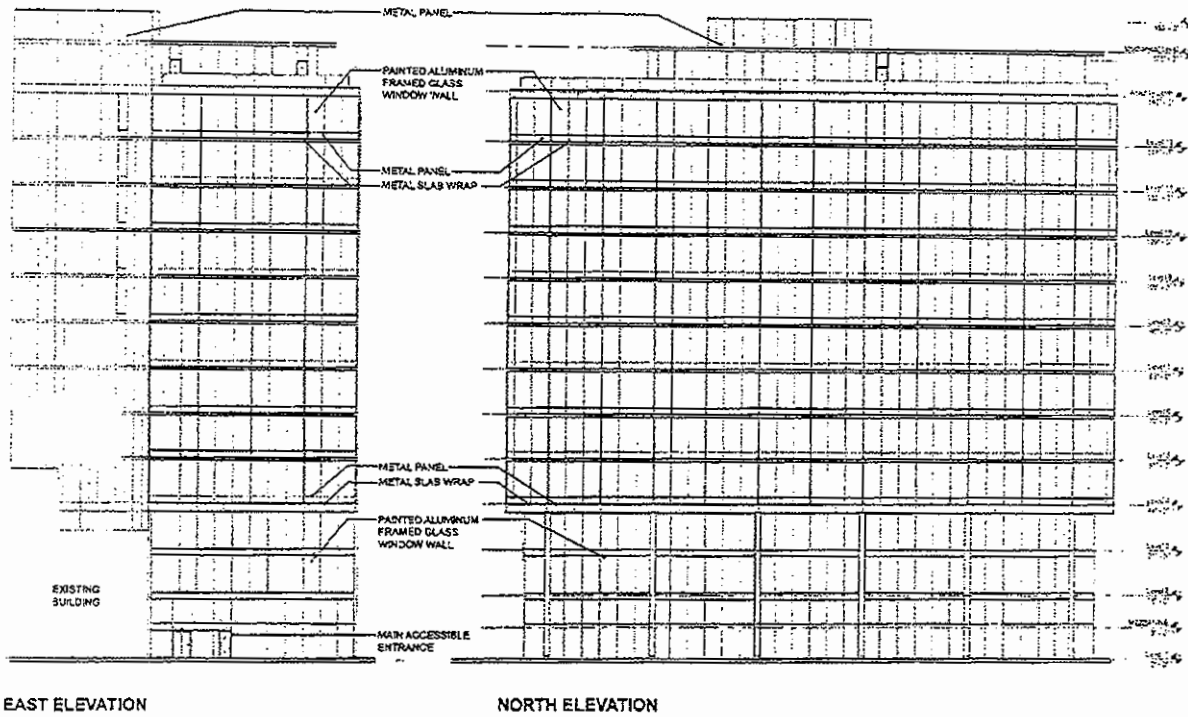

ELEVATIONS

Applicant: 430 North LaSalle LLC
 Address: 151 W Illinois; 430 - 500 N LaSalle Drive
 Introduced: January 23, 2019
 CPC Date: April 18, 2019



Final for Publication

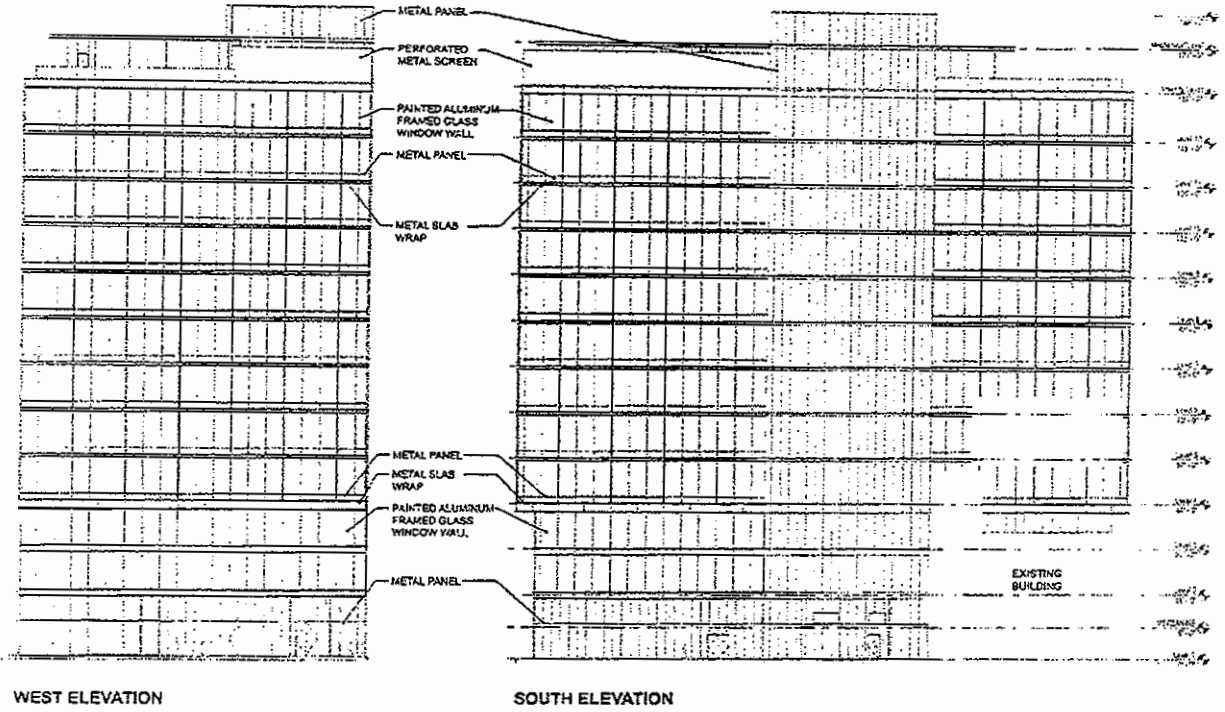

ELEVATIONS

Applicant: 430 North LaSalle LLC
 Address: 151 W Illinois; 430 - 500 N LaSalle Drive
 Introduced: January 23, 2019
 CPC Date: April 18, 2019



FINAL FOR PUBLICATION

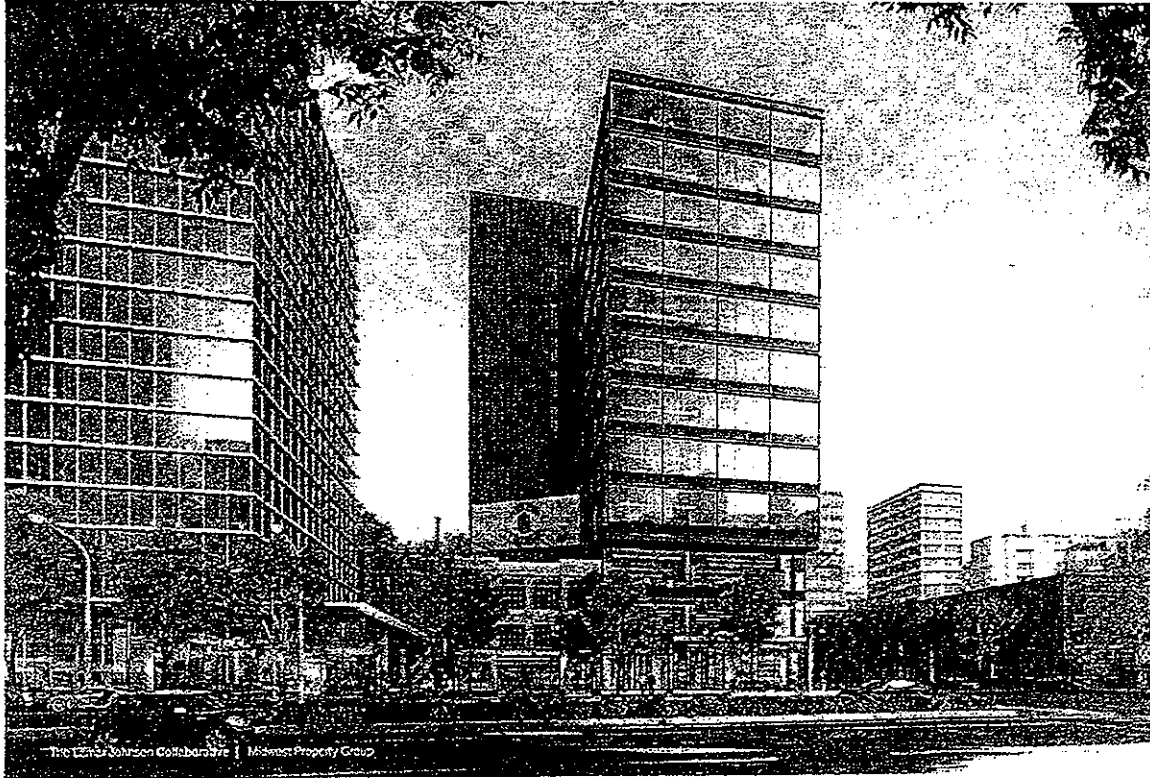

CONTEXTUAL RENDERINGS

Applicant: 430 North LaSalle LLC
 Address: 151 W Illinois; 430 - 500 N LaSalle Drive
 Introduced: January 23, 2019
 CPC Date: April 18, 2019



FINAL FOR PUBLICATION

7/24/2019

REPORTS OF COMMITTEES

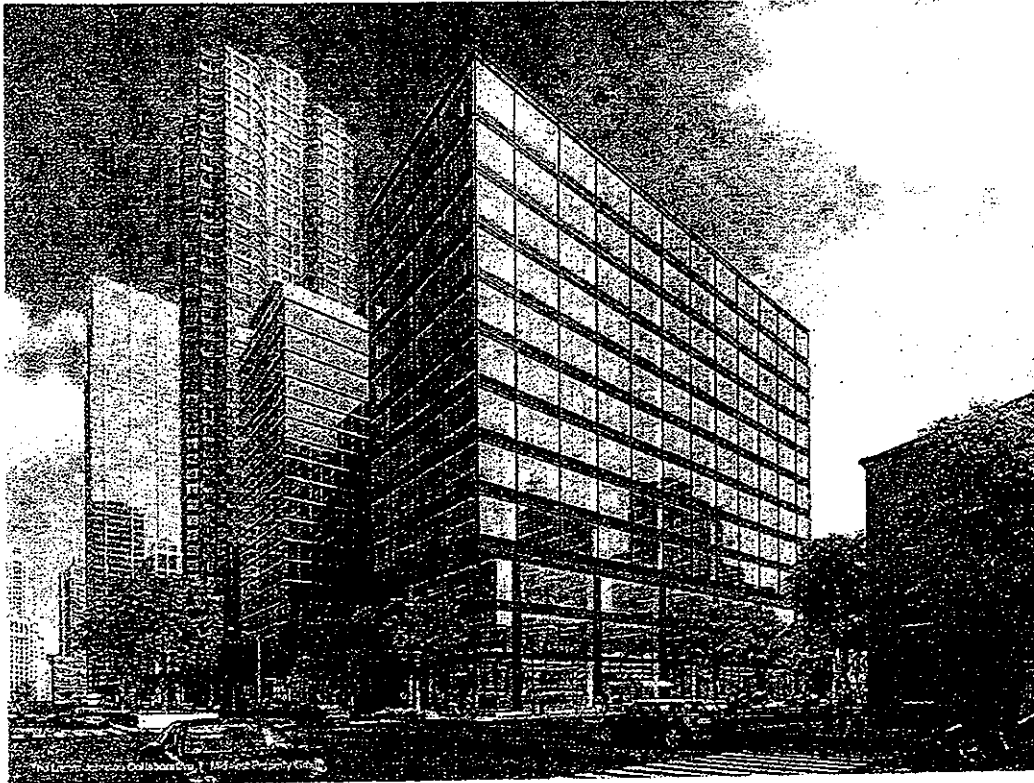

CONTEXTUAL RENDERINGS

Applicant: 430 North LaSalle LLC
Address: 151 W Illinois; 430 - 500 N LaSalle Drive
Introduced: January 23, 2019
CPC Date: April 18, 2019



FINAL FOR PUBLICATION



EXISTING PHOTO - LOOKING WEST



EXISTING PHOTO - LOOKING NORTH

EXISTING SITE PHOTOS

Applicant: 430 North LaSalle LLC
Address: 151 W Illinois; 430 - 500 N LaSalle Drive
Introduced: January 23, 2019
CPC Date: April 18, 2019



FINAL FOR PUBLICATION



EXISTING PHOTO - LOOKING SOUTHWEST



EXISTING PHOTO - LOOKING SOUTHEAST

EXISTING SITE PHOTOS

Applicant: 430 North LaSalle LLC
Address: 151 W Illinois; 430 - 500 N LaSalle Drive
Introduced: January 23, 2019
CPC Date: April 18, 2019



FINAL FOR PUBLICATION

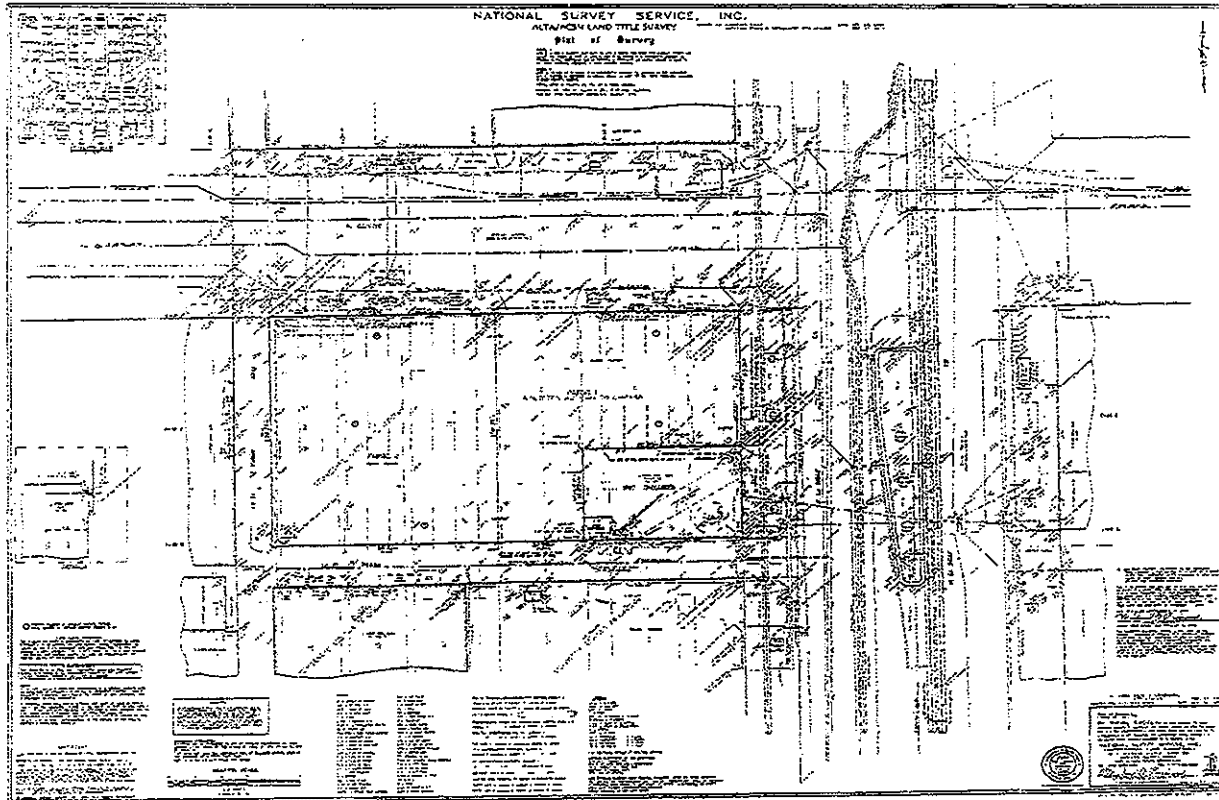

SURVEY SUB AREA A

Applicant: 430 North LaSalle LLC
Address: 151 W Illinois; 430 - 500 N LaSalle Drive
Introduced: January 23, 2019
CPC Date: April 18, 2019



FINAL FOR PUBLICATION

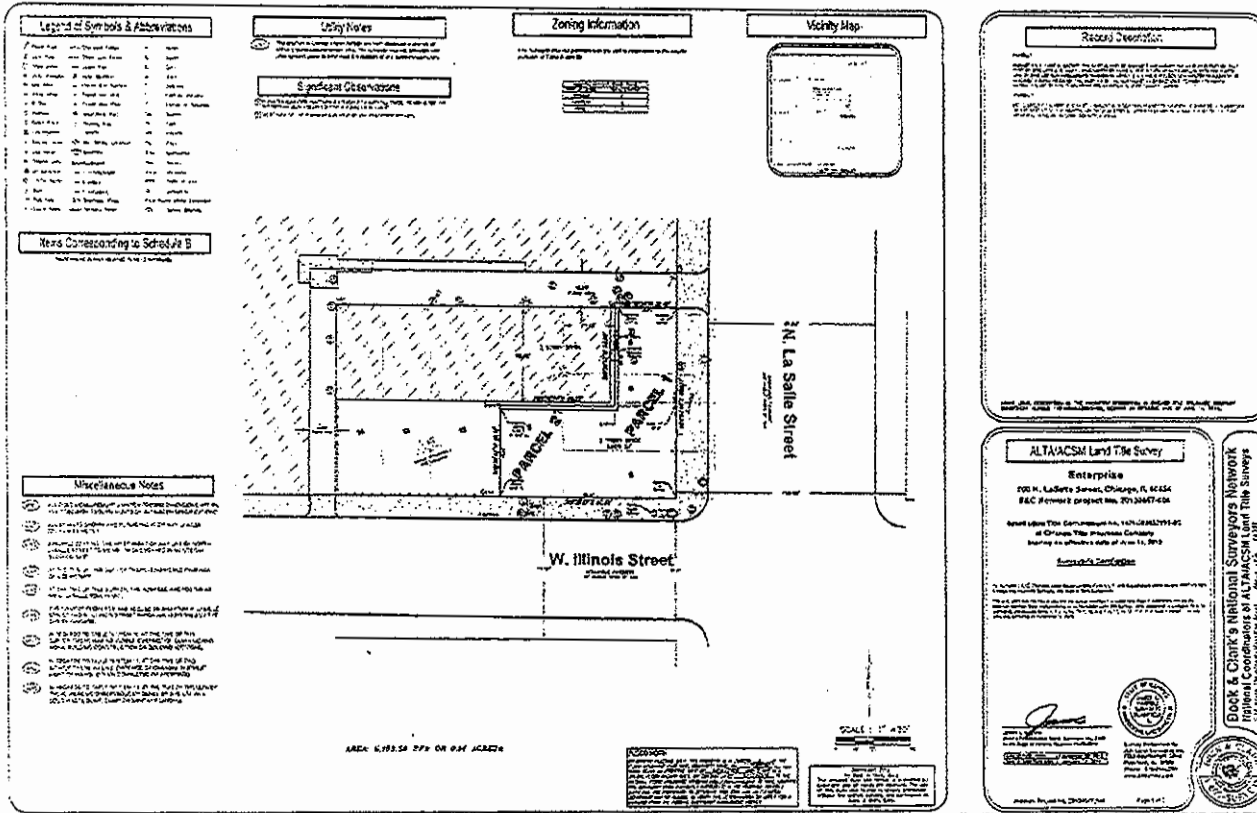

SURVEY SUB AREA B

Applicant: 430 North LaSalle LLC
 Address: 151 W Illinois; 430 - 500 N LaSalle Drive
 Introduced: January 23, 2019
 CPC Date: April 18, 2019



FINAL FOR PUBLICATION

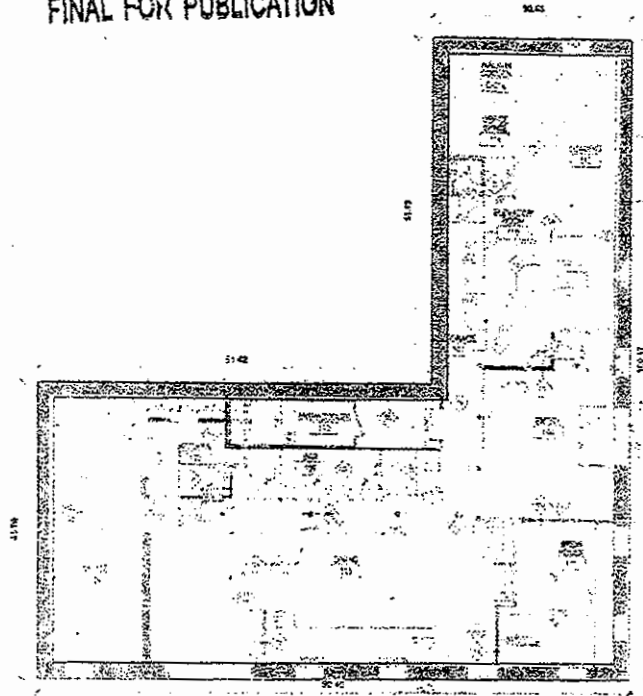

FLOOR PLAN SUB AREA B - 500 N LASALLE

Applicant: 430 North LaSalle LLC
 Address: 151 W Illinois; 430 - 500 N LaSalle Drive
 Introduced: January 23, 2019
 CPC Date: April 18, 2019

22 430 N LASALLE, LLC | LAMAR JOHNSON COLLABORATIVE

February 27, 2019



Final for Publication

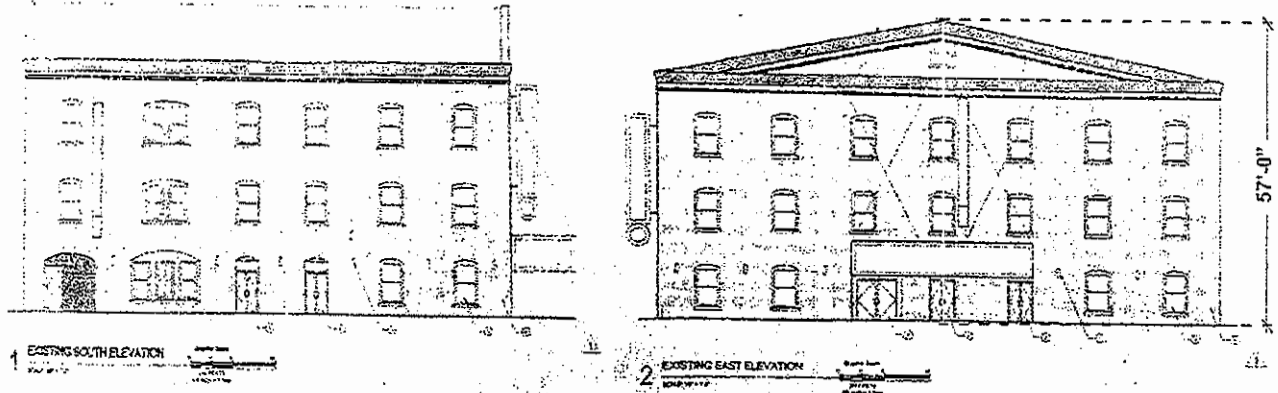

ELEVATIONS SUB AREA B - 500 N LASALLE

Applicant: 430 North LaSalle LLC
 Address: 151 W Illinois; 430 - 500 N LaSalle Drive
 Introduced: January 23, 2019
 CPC Date: April 18, 2019

